

# ADC-11 Terminal Board

## User's Guide

Issues:

- 1) Obsolete.
- 2) Obsolete.
- 3) 13.11.03. A5 Word format. Not issued.
- 4) 28.3.06. Erie format. Typographic errors fixed.
- 5) 12.7.07. Chantilly format. D0 output description amended.
- 6) 30.1.08. James House address. New heading styles.

**Pico Technology**

James House  
Colmworth Business Park  
Eaton Socon  
ST. NEOTS  
Cambridgeshire  
PE19 8YP  
United Kingdom

Tel: +44 1480 396395  
Fax: +44 1480 396296  
Email: [post@picotech.com](mailto:post@picotech.com)

© Copyright 2006-2008 Pico Technology. All rights reserved.

**CONTENTS**

1	Overview	1
1.1	Introduction	1
1.2	Terminals and component sites	2
1.3	Connecting to the data logger	2
2	Taking measurements	3
2.1	Voltage	3
2.1.1	General	3
2.1.2	Direct connection	3
2.1.3	Voltage divider connection	4
2.2	Current	6
2.3	Light level	6
2.4	Temperature	7
2.4.1	Introduction	7
2.4.2	LM35DZ IC	7
2.4.3	Precision thermistor	8
2.4.4	Thermocouple	9
	Appendix 1 – Thermistor conversion table	11
	Appendix 2 – Thermocouple conversion table	11



# 1 Overview

## 1.1 Introduction

The ADC-11 Terminal Board is an accessory for the 11-channel ADC-11 Data Logger. It enables you to build sensor circuits that take measurements for the data logger to process. The screw terminals allow sensor wires to be attached direct to the board without the need for solder.

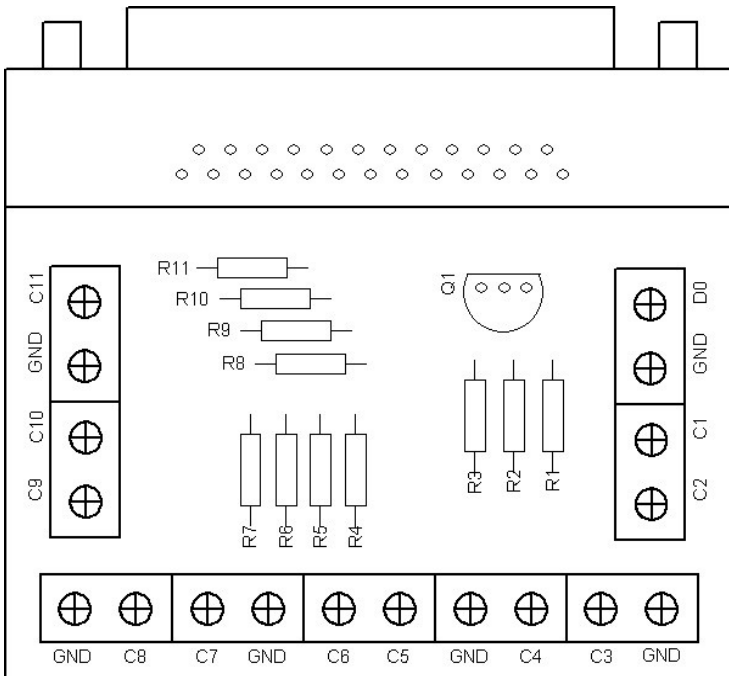

**ADC-11 Terminal Board**

## 1.2 Terminals and component sites

The table below shows the purpose of each of the terminals and empty component sites.

<b>Terminal or site</b>	<b>Description</b>
C1 to C11	Connections to ADC channels 1 to 11.
D0	Digital output. If you write your own application you can use this as a low-current supply to power sensors.
GND	Connection to ground.
Q1	Site for LM35 temperature sensor. See Section 2.4.2.
R1 to R3	Sites for resistors between D0 and channels 1 to 3.
R4 to R7	Sites for series resistors in inputs to channels 5 to 8. Shown as $R_A$ in the text. If you fit a resistor in one of these sites, you must cut the corresponding thin track on the back of the circuit board.
R8 to R11	Sites for shunt resistors between channels 5 to 8 and GND. Shown as $R_B$ in the text.

### Terminals and component sites

## 1.3 Connecting to the data logger

You can plug the Terminal Board directly into the analog connector on the ADC-11 Data Logger, or you can use a standard 25-way male-D to female-D parallel cable to connect the two units.

## 2 Taking measurements

### 2.1 Voltage

#### 2.1.1 General

You can use the ADC-11 Terminal Board with the ADC-11 to measure voltages in two ways: directly, by plugging straight into the channel, or indirectly, via a voltage divider.

#### 2.1.2 Direct connection

For voltage sources measuring from 0 V to +2.5 V, use a direct connection to any channel.

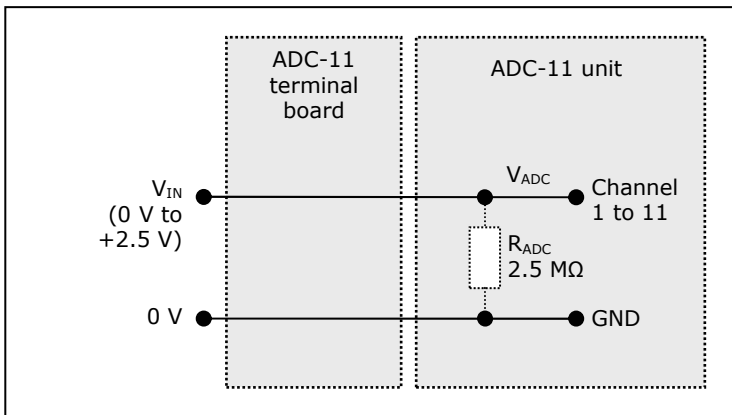

**Direct input to channel**

### 2.1.3 Voltage divider connection

For voltages beyond 0 V to +2.5 V, use a voltage divider connection.

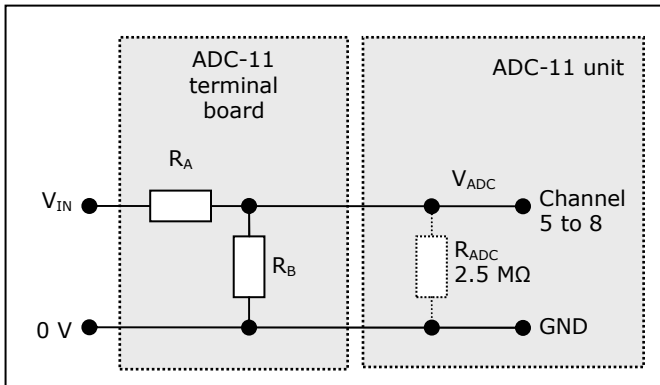

**Voltage divider**

The voltage that the ADC sees,  $V_{ADC}$ , depends on  $V_{IN}$  and the values of  $R_A$  and  $R_B$ , and is given by the following equation:

$$V_{ADC} = \frac{V_{IN} R_B}{R_A + R_B}$$

Choose values of  $R_A$  and  $R_B$  so that  $V_{ADC}$  is approximately +2.5 V when  $V_{IN}$  is at its highest.

To minimise errors in the measured voltage,  $V_{ADC}$ , caused by loading of the source voltage  $V_{IN}$ , ensure that the combined resistance of  $R_A + R_B$  is much greater than the resistance of the voltage source. If you are unsure of the resistance of the voltage source, use large values for  $R_A$  and  $R_B$  such that  $R_A + R_B$  is about 10 k $\Omega$ .

If you have chosen a value for  $R_B$  that is greater than 10 k $\Omega$ , and you need high accuracy, then you will need to take into account the ADC's input resistance  $R_{ADC}$ , which is in parallel with  $R_B$ . Use the following equation to obtain a value for the parallel equivalent resistance of  $R_B$  and  $R_{ADC}$ ,  $R_{BADC}$ :

$$R_{BADC} = \frac{R_B R_{ADC}}{R_B + R_{ADC}}$$

where  $R_{ADC} = 2.5 \text{ M}\Omega$ , then use  $R_{BADC}$  instead of  $R_B$  in the previous equation.



The following four noise problems are often associated with potential divider circuits:

- 1) **Noise from source voltage.** Try fitting a capacitor as described below.
- 2) **RF interference picked up at high impedance points.** Smaller values for  $R_A$  and  $R_B$  may help.
- 3) **Noise on the earth connections.**
- 4) **The signal 0 V line is connected to mains earth.** Try to avoid this situation.

Should either 1) or 2) above occur, and you want to try a capacitor, ensure that you have fitted resistor  $R_A$  and cut the corresponding track beneath the resistor. Fit the capacitor in place of or in parallel with  $R_B$ , as necessary. Use the following equation for  $C$ , the value of the capacitor:

$$C = \frac{1}{2\pi f R}$$

where  $R$  is  $R_A$  or the smaller of  $R_A$  and  $R_B$ , and  $f$  is the highest signal frequency in hertz.

## 2.2 Current

You can use the ADC-11 Terminal Board with the ADC-11 to measure current towards ground, using a simple shunt resistor to convert the current into a voltage before measuring with the ADC. The diagram below shows a circuit with a shunt resistor  $R_B$ .

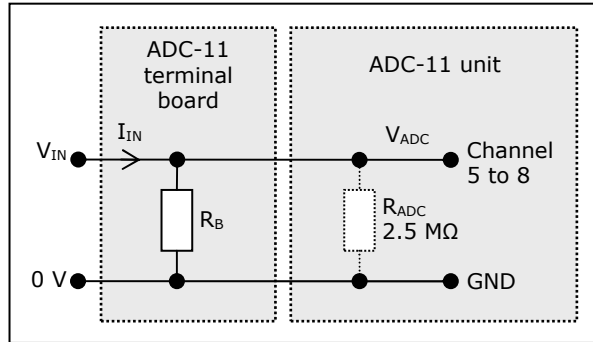

**Shunt resistor circuit**

The locations for  $R_B$  appear as R8 to R11 in the diagram of the terminal board at the start of this booklet. You will need to calculate the resistor value  $R_B$  from the following equation:

$$R_B = \frac{2.5 \text{ V}}{I_{MAX}}$$

where  $I_{MAX}$  is the highest current you expect to measure.

### **Warning!**

**Under no circumstances use this method for measuring mains currents. The ADC-11 Terminal Board is not designed to be connected to the mains. Attempting to do so could result in serious personal injury or property damage.**

## 2.3 Light level

You can use the ADC-11 Terminal Board with channels 5 to 8 of the ADC-11 to measure light levels. You will also need a light-dependent resistor (LDR) and a fixed resistor.

Use the digital output to supply power to the circuit. Use a resistor of around  $1 \text{ M}\Omega$  for  $R_A$ , and place the LDR in location  $R_B$ .

## 2.4 Temperature

### 2.4.1 Introduction

You can measure temperatures accurately using the ADC-11 Terminal Board and ADC-11 with a suitable sensor and the PicoLog software. Three types of sensor can be used:

LM35DZ integrated circuit sensor

Precision thermistor

Thermocouple used with AD595 integrated circuit

Note: If you require several temperature sensors, Pico Technology's TC-08 thermocouple interface is a better product to use, as it allows you to plug in up to eight thermocouples.

### 2.4.2 LM35DZ IC

The LM35DZ IC is a combined precision temperature sensor and signal conditioner supplied in a three-pin TO92 package. Of the three devices, this is the easiest to connect to the ADC. The device measures temperatures in the range 0°C to +100°C and includes the electronics required to convert temperatures to a linear voltage of 10 mV/°C. The diagram below shows how to connect this device to the terminal board.

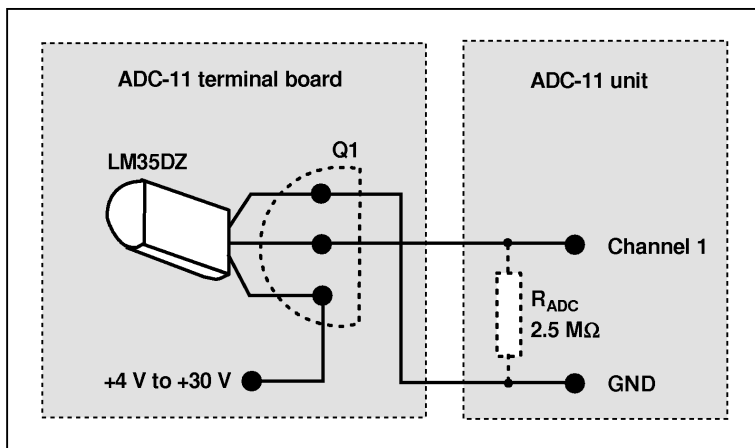

**Temperature sensor circuit with LM35DZ IC**

Fit the LM35DZ to the terminal board in position Q1. To convert the voltage to a temperature reading, use PicoLog's scaling equation facility. Set the scaling equation to:  $X * 100$ . For more information, see PicoLog's electronic manual (PLW044.PDF in your Pico Technology installation directory).

### 2.4.3 Precision thermistor

You can use a precision thermistor in conjunction with the reference output of the ADC-11 for accurate temperature measurement.

A +5 V supply can be taken from the terminal board. This is converted to a stable and precise +2.5 V using the LM4040 voltage reference. To calculate the value of the thermistor, use this stable voltage in conjunction with a known resistor value.

You will need to consult the table in Appendix 1 before using PicoLog to convert the voltages into temperature readings. The figures come from the thermistor manufacturer's data sheet.

The diagram below shows how to connect the thermistor, shown as  $R_B$ , to the terminal board.

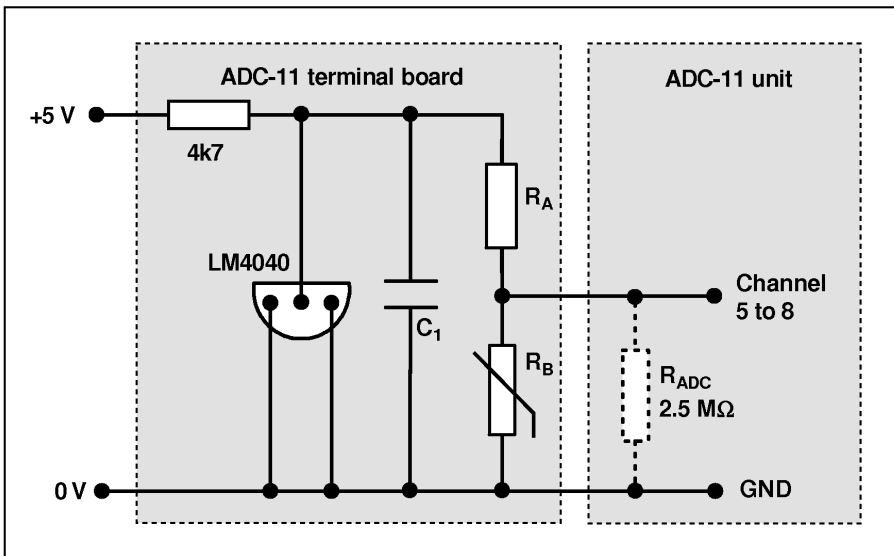

### Temperature sensor circuit with precision thermistor

The thermistor is an NTC (negative temperature coefficient) type with a -80°C to +150°C temperature range. Resistor  $R_A$  is a precision metal film type with a value of 49.9 kΩ and a tolerance of 0.1%.

Capacitor C<sub>1</sub> should be 1 μF or greater, with at least a 3 V rating.

The table of values in Appendix 1 shows that maximum resolution is about 0.1°C at 40°C for the ADC-11.

2.4.4 Thermocouple

The ADC-11 can be used with a thermocouple and an AD595 IC. The circuitry involved in connecting these to the ADC is more complex than the previous types and should be constructed with care.

The AD595 IC is an integrated thermocouple instrumentation amplifier with built-in cold junction compensation. The diagram below shows how to connect the AD595 IC and the thermocouple to the terminal board. The output voltage is not linear with temperature, so you will need to consult the table in Appendix 2 to convert the voltages to temperatures.

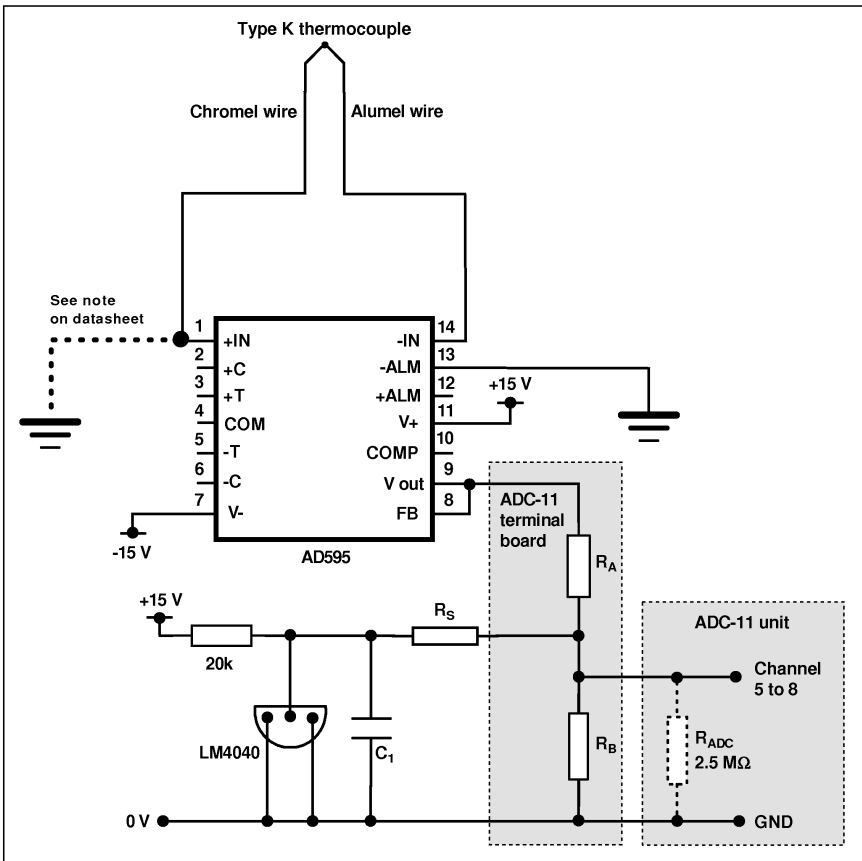

**Temperature sensor circuit with thermocouple and AD595**

Note: The AD595 will require a separate power supply. For full details of the AD595, see the Analog Devices website at [www.analog.com](http://www.analog.com). Please observe electrostatic discharge (ESD) precautions when constructing this circuit, to avoid damage to the AD595.

The circuit shown can measure temperatures in the range  $-200^{\circ}\text{C}$  to  $+1250^{\circ}\text{C}$ . The component values are as follows:

$R_A = 44.2\text{ k}\Omega$  0.1% metal film

$R_B = 11\text{ k}\Omega$  0.1% metal film

$R_S = 75\text{ k}\Omega$  0.1% metal film

$C1 = 1\text{ }\mu\text{F}$  or greater with at least 3 V rating.

## Appendix 1 – Thermistor conversion table

Temp. (°C)	V <sub>ADC</sub> (V)	Temp. (°C)	V <sub>ADC</sub> (V)	Temp. (°C)	V <sub>ADC</sub> (V)
-30	2.441	30	1.535	100	0.251
-20	2.392	40	1.264	110	0.189
-10	2.311	50	1.006	120	0.143
0	2.189	60	0.779	130	0.109
10	2.016	70	0.593	140	0.084
20	1.794	80	0.446	150	0.065
25	1.668	90	0.334		

## Appendix 2 – Thermocouple conversion table

Temp. (°C)	V <sub>ADC</sub> (V)	Temp. (°C)	V <sub>ADC</sub> (V)	Temp. (°C)	V <sub>ADC</sub> (V)
-200	0.003	180	0.587	660	1.474
-180	0.018	200	0.622	760	1.658
-160	0.036	220	0.657	780	1.695
-140	0.057	240	0.693	800	1.731
-120	0.081	260	0.729	820	1.767
-100	0.107	280	0.765	840	1.803
-80	0.135	300	0.802	860	1.838
-60	0.164	320	0.856	880	1.874
-40	0.196	340	0.875	900	1.909
-20	0.229	360	0.912	920	1.944
-10	0.246	380	0.949	940	1.979
0	0.263	400	0.984	960	2.014
10	0.281	420	1.024	980	2.049
20	0.298	440	1.061	1000	2.083
25	0.307	460	1.098	1020	2.117
30	0.316	480	1.136	1040	2.151
40	0.334	500	1.173	1060	2.185
50	0.352	520	1.211	1080	2.221
60	0.371	540	1.249	1100	2.253
80	0.407	560	1.286	1120	2.286
100	0.444	580	1.324	1140	2.319
120	0.480	600	1.361	1160	2.352
140	0.516	620	1.399	1180	2.384
160	0.552	640	1.436	1200	2.417